

Scientific Achievements of Dr. Rüdiger Paschotta

Dr. Rüdiger Paschotta RP Photonics Consulting GmbH

This document gives an overview on the most important scientific achievements of Dr. Rüdiger Paschotta.

Use the publication list in the curriculum vitae (http://www.rp-photonics.com/CV_Paschotta.pdf) to obtain the complete picture.

Overview on Research Occupations

- 12/1990 to 09/1994: diploma/Ph. D. student at the University of Konstanz, Germany, in the group of J. Mlynek, working on the generation of nonclassical states of light in nonlinear optical devices
- 09/1994 to 01/1997: post-doc at the Optoelectronics Research Centre in Southampton, England, in the group of D. C. Hanna and A. C. Tropper, working on fiber lasers and amplifiers
- 02/1997 to 10/1997: post-doc at the University of Paderborn, Germany, in the group of W. Sohler, working on integrated nonlinear optical devices
- 11/1997 until 06/2005: senior research assistant at ETH Zürich, Switzerland, supervising the “all-solid-state laser group” within the group of U. Keller, working on mode-locked lasers with high output power and/or multi-GHz pulse repetition rates, some nonlinear optics, and noise in mode-locked lasers

Overview on Topics

- Fiber lasers and amplifiers
- Mode-locked lasers
 - Ultrashort pulses from high-power lasers
 - Passively mode-locked lasers with multi-GHz repetition rates
- Q-switched microchip lasers
- Nonlinear optics
- Fluctuations and noise
 - Nonclassical states of light
(quantum noise reduction in nonlinear devices)
 - Timing jitter and phase noise of mode-locked lasers
- Lasers, general

Remarks on Joint Achievements

Many of the results presented here came about in the collaboration of R. Paschotta with other researchers – most often with the Ph. D. students working under his supervision. This is reflected in the first authorships of the quoted citations. In any of the listed cases, R. Paschotta has played an important role not only in planning, but also in the scientific details.

Fiber Lasers and Fiber Amplifiers

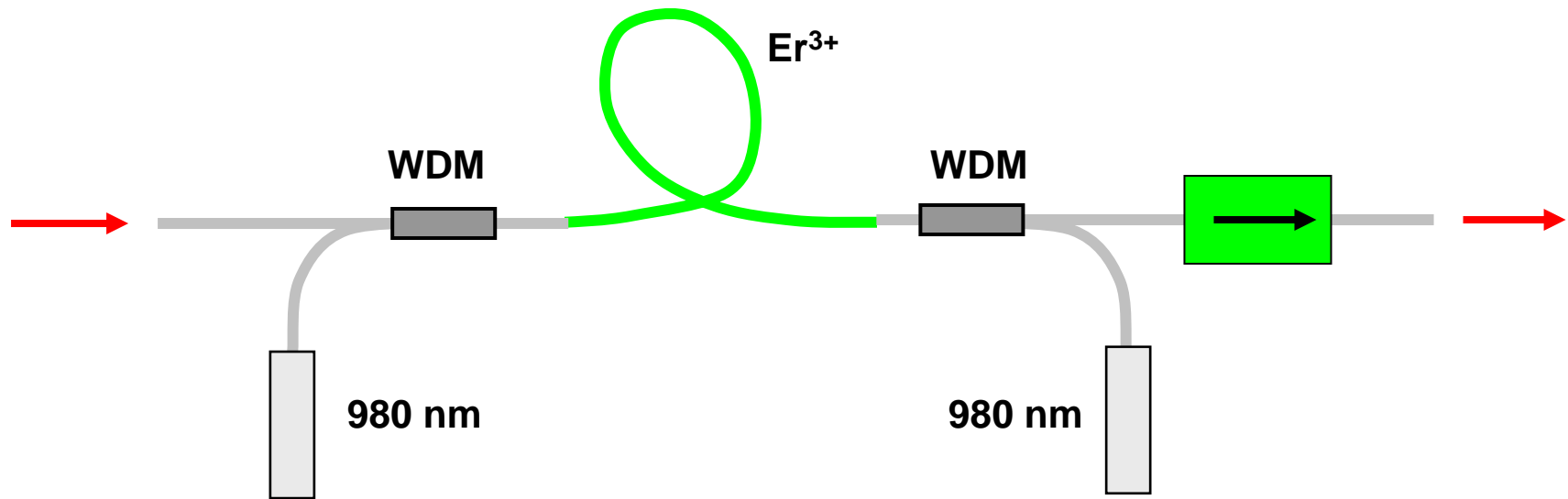

Modeling of Blue Upconversion Lasers

- Principle of upconversion in thulium-doped ZBLAN fibers: sequential absorption of three pump photons, stimulated emission of a single (blue) photon with higher energy

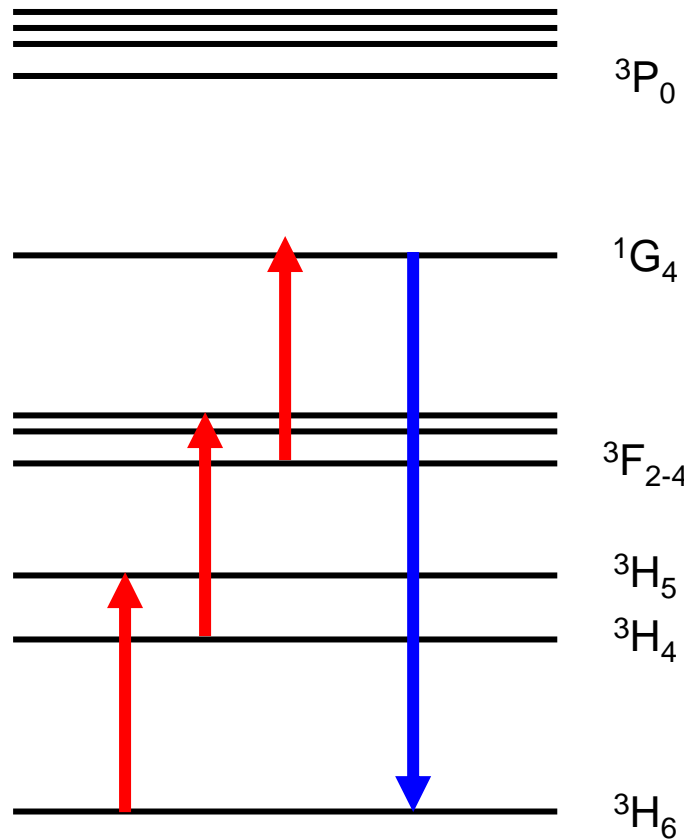

Tm³⁺ level scheme.

Not shown:
a multitude of energy transfer processes which have been included in a numerical model and tested with spectroscopic experiments

Modeling of Blue Upconversion Lasers

- Challenge: complicated interplay of various processes
- What was done: comprehensive model calculating the population of various thulium energy levels and the propagation of pump and laser power in the fiber; various measurements to obtain spectroscopic data
- Achievements: working model which allowed to understand and optimize the performance of blue lasers, leading to a world-record result with 230 mW output power and contributing to the identification of previously unknown parasitic processes
- Refs.:
 - R. Paschotta et al., J. Opt. Soc. Am. B **14** (5), 1213 (1997)
 - R. Paschotta et al., IEEE J. Sel. Topics on Quantum Electron. 3 (4), 1100 (1997) (invited)
 - P. R. Barber et al., Opt. Lett. **20** (21), 2195 (1995)

Yb-doped Fiber Lasers and Amplifiers

- Achievements:
 - Discovery of an unexpected quenching effect related to color centers in the glass matrix, which can be very detrimental to the performance of lasers and amplifiers
(R. Paschotta et al., Opt. Commun. **136**, 243 (1997))
 - Important design guidelines for fiber amplifiers
(R. Paschotta et al, IEEE J. Quantum Electron. **33** (7), 1049 (1997))
 - Contributions to the invention of a new fiber design
(J. Nilsson et al., Opt. Lett. **22** (14), 1092 (1997))
 - Demonstration of high-performance superluminescent source
(R. Paschotta et al., IEEE J. Sel. Topics on Quantum Electron. **3** (4), 1097 (1997))
 - Identification and demonstration of a strange situation where spatial hole burning serves to stabilize single-frequency operation
(R. Paschotta et al, Opt. Lett. **22** (1), 40 (1997))

Passively Q-switched Er-doped Fiber Laser System

- Previously, Q-switched fiber lasers system were typically limited to pulse energies in the nanojoule regime
- Achievement: demonstration of an erbium-doped laser/amplifier system, generating $>100\text{-}\mu\text{J}$ pulses with a single pump source
- Key points: use of novel large mode area fiber; optimization of saturable absorber for Q-switched laser; use of a novel laser/amplifier configuration for high pulse energies with a single pump source

Ref.: R. Paschotta et al., Opt. Lett. **24** (6), 388 (1999)

Mode-Locked Lasers with Very High Output Powers

- Previously, the average output power of mode-locked lasers was limited to the order of 1 W. Significantly more is desirable for various applications.
- Particularly in the sub-picosecond regime of pulse durations, a load of challenging problems seemed to inhibit significant progress towards high powers: thermal effects in gain media, damage of saturable absorbers, Q-switching instabilities, etc.
- Achievements: invention and demonstration of a power-scalable femtosecond laser concept, the passively mode-locked thin disk laser. This resulted in record-high average output powers of up to 80 W directly from a laser (without amplifier) and enabled the demonstration of a variety of high-power nonlinear devices.
- Key points: thorough understanding of the complicated interplay of physical effects and design aspects; development and systematic use of powerful modeling and numerical optimization tools

Mode-Locked Lasers with Very High Output Powers

- Refs.:
 - J. Aus der Au, Opt. Lett. **25** (11), 859 (2000)
 - R. Paschotta et al., Appl. Phys. B **70**, S25 (2000)
 - R. Paschotta et al., Appl. Phys. B **72** (3), 267 (2001)
 - F. Brunner et al., Opt. Lett. **26** (6), 379 (2001)
 - E. Innerhofer et al., Opt. Lett. **28** (5), 367 (2003)
 - F. Brunner et al., Opt. Lett. **29** (16), 1921 (2004)

Mode-Locked Lasers with Multi-GHz Repetition Rates

10-GHz laser

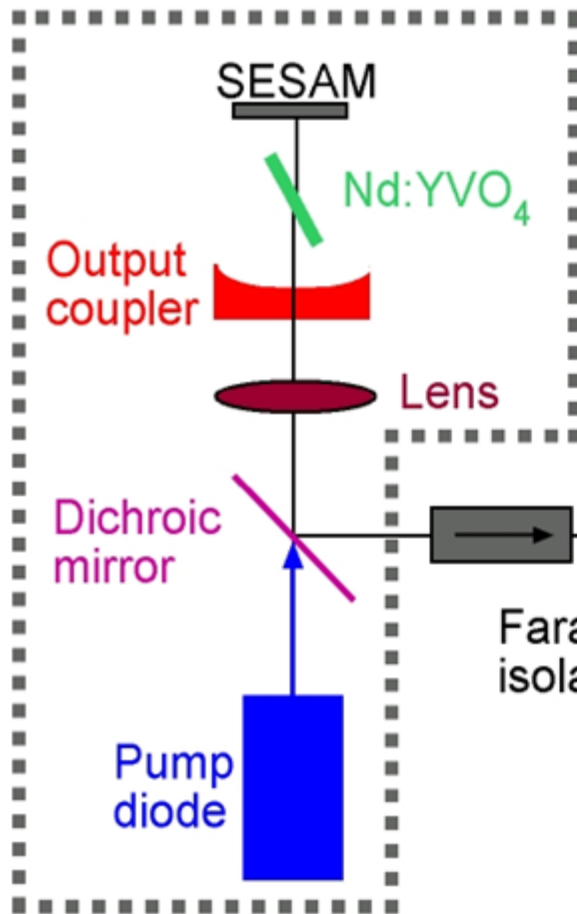

10-GHz **non**-monolithic OPO

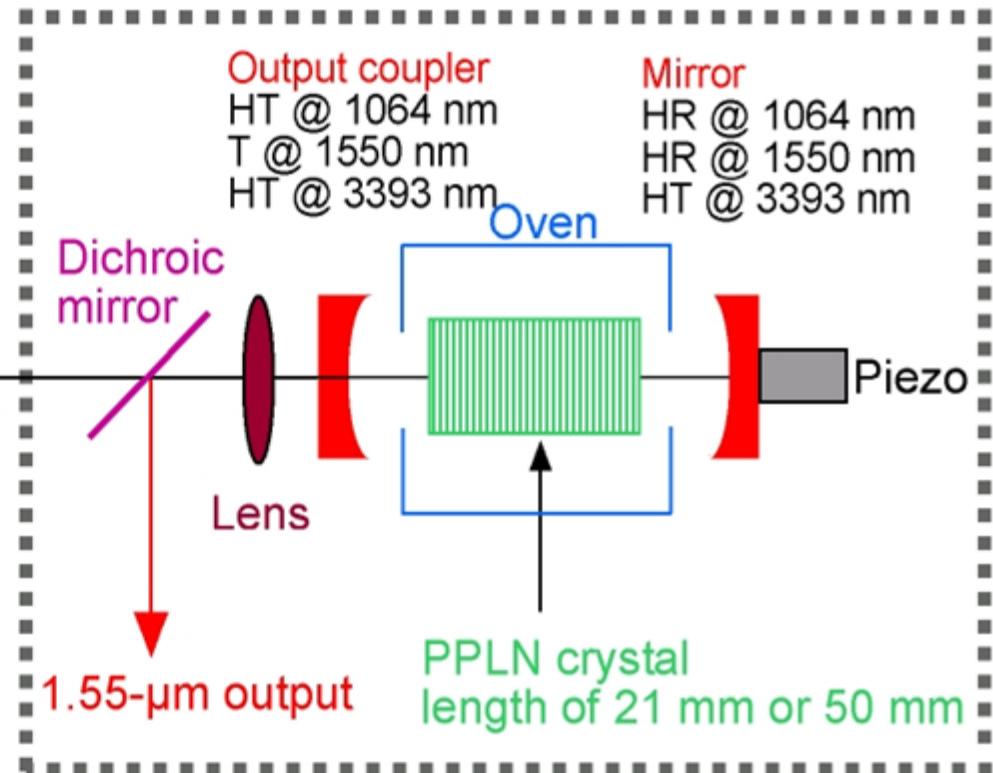

Mode-Locked Lasers with Multi-GHz Repetition Rates

- Pulse trains with multi-GHz repetition rates are required for applications in telecommunications, optical sampling, home cinema devices, etc.
- Previously existing devices were often limited in output power or pulse quality
- Achievements: development of various novel laser sources generating multi-GHz picosecond pulses with high quality and high output power, all exhibiting record-level performance:
 - Nd:YVO₄ lasers in the 1- μ m region with up to \approx 160 GHz
 - Er:Yb:glass lasers in the 1.5- μ m region with up to \approx 50 GHz
 - Novel surface-emitting semiconductor lasers (VECSELs) in the 0.95- μ m region for multi-watt output in picosecond pulses (see later slides)
 - Synchronously pumped parametric oscillators with up to 82 GHz repetition rate

Multi-GHz Er:Yb:Glass Lasers

- Multi-GHz sources in the 1.5- μm spectral region are required for telecom applications
- Previously, diode-pumped solid-state lasers could not be operated in this regime (only with far lower repetition rates)
- Achievement: developed 1.5- μm Er:Yb:glass miniature lasers operating with up to 50 GHz – far higher than previously believed to be feasible
- Key points: construction of miniature laser setups; optimization of saturable absorber technology; advanced laser modeling; spin-off company GigaTera AG was founded to commercialize these lasers.
- Refs.:
 - L. Krainer et al., Electron. Lett. **38** (5), 225 (2002)
 - S. C. Zeller et al., Appl. Phys. B **76**, 787 (2003)
 - S. C. Zeller et al., Electron. Lett. **40** (14), 875 (2004)

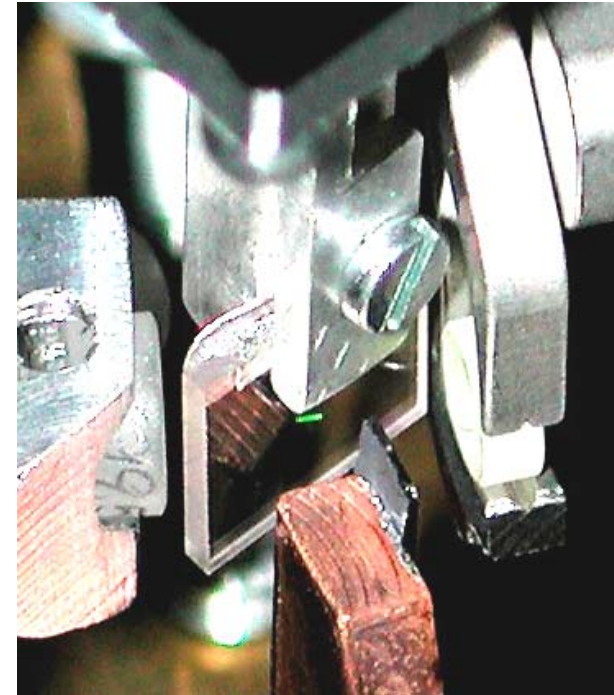

High-Power Mode-Locked Surface-Emitting Semiconductor Lasers

- Edge-emitting semiconductor lasers are very limited in output power, when good beam quality is required (as e.g. for pulse generation)
- Surface-emitting semiconductor lasers with external cavity have the potential for multi-watt output powers
- Achievement: first demonstration of a passively mode-locked optically pumped surface-emitting semiconductor laser; optimization of such devices for e.g. as much as 1.4 W output power in a 10-GHz 6-ps pulse train

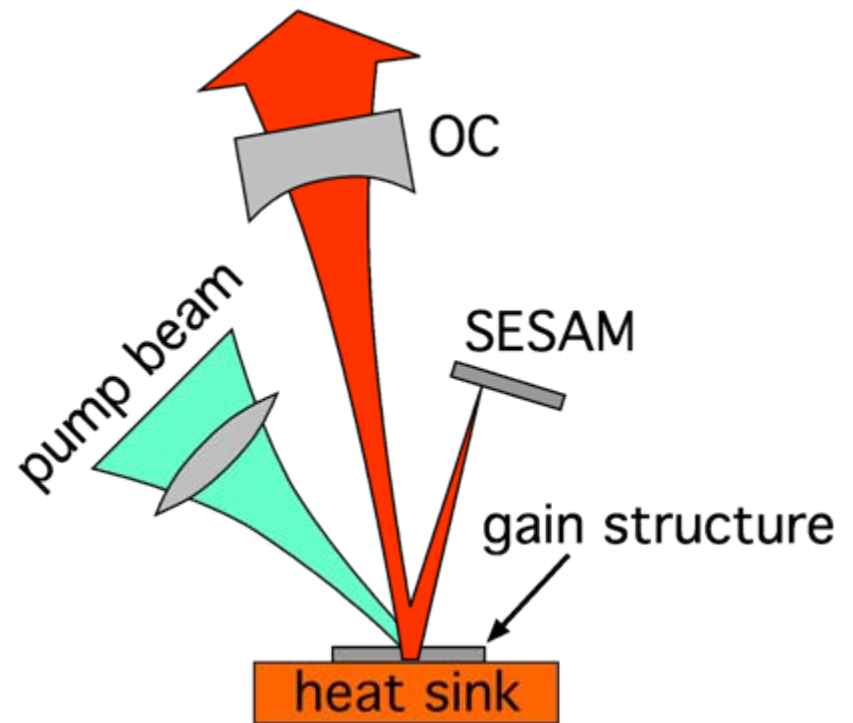

High-Power Mode-Locked Surface-Emitting Semiconductor Lasers

- Key points: identification of the potential of this new technological approach; advanced design methods for semiconductor gain structures; development of device processing; optimization of laser setups based on theoretical understanding of thermal issues, pulse shaping dynamics, etc.
- Refs.:
 - S. Hoogland et al., IEEE J. Photon. Technol. Lett. **12** (9), 1135 (2000)
 - R. Häring et al., IEEE J. Quantum Electron. **38** (9), 1268 (2002)
 - D. Lorensen et al., Appl. Phys. B **79**, 927 (2004)
 - A. Aschwanden et al., Appl. Phys. Lett. **86**, 131102 (2005)
 - A. Aschwanden et al., Opt. Lett. **30** (3), 272 (2005)

Q-Switched Microchip Lasers

- Principle: compact laser with output coupler and saturable absorber device mounted directly on both faces
- Achievements: obtained thorough theoretical understanding by verification of detailed models; used this knowledge to obtain record performance levels, e.g. pulses as short as 37 ps
- Refs.:
 - G. J. Spühler et al., J. Opt. Soc. Am. B **16** (3), 376 (1999)
 - G. J. Spühler et al., Appl. Phys. B **72** (3), 285 (2001)
 - R. Häring et al., J. Opt. Soc. Am. B **18** (12), 1805 (2001)

Nonlinear Optics

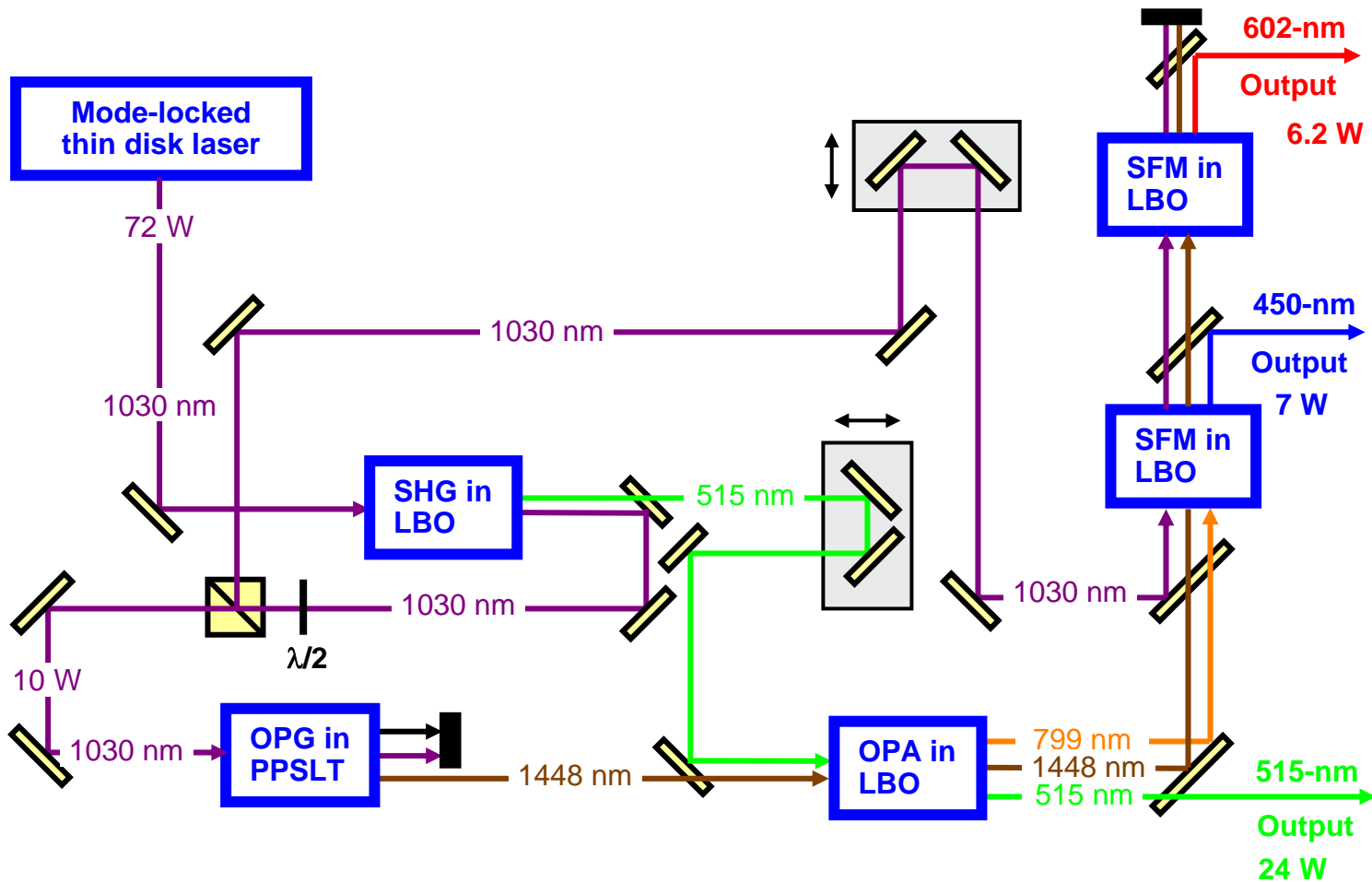

Highly Efficient Frequency Doublers

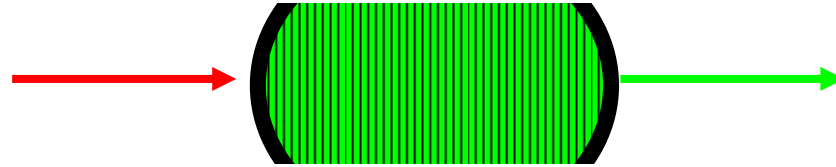

- Achievement: development of highly efficiency monolithic frequency doublers with up to 82% conversion efficiency from infrared to green light
- Key points: detailed design studies and systematic characterization efforts
- Ref.: R. Paschotta et al., Opt. Lett. **19** (17), 1325 (1994)

Multi-GHz Parametric Oscillators

- Broadly wavelength-tunable pulse sources with multi-GHz repetition rates are required e.g. for telecom applications
- Synchronously pumped OPOs (optical parametric oscillators) are broadly wavelength-tunable, but have previously been limited to at most a few GHz
- Achievements: pushed the repetition rate of parametric oscillators to 10 GHz and then to 40 GHz
- Key points: development of optimized diode-pumped pump sources; optimization of OPO cavities
- Refs.:
 - S. Lecomte et al., Opt. Lett. **27** (19), 1714 (2002)
 - S. Lecomte et al., J. Opt. Soc. Am. B **21** (4), 844 (2004)
 - S. Lecomte et al., Opt. Lett. **30** (3), 290 (2005)
 - S. Lecomte et al., Photon. Technol. Lett. **17**, 483 (2005)

High-Power RGB System

- High-power laser source with red, green and blue outputs is required for large-scale cinema displays and flight simulators
- Achievement: developed a novel system with record-high output powers and reduced complexity compared to previous approaches.
- Key points: development of high-power mode-locked laser (so that amplifiers are not required); critical phase matching for operation of nearly all nonlinear crystals at room temperature; two-stage parametric generator approach for high power and good beam quality
- Refs.:
 - F. Brunner et al., Opt. Lett. **29** (16), 1921 (2004)
 - E. Innerhofer et al., J. Opt. Soc. Am B **23** (2), 265 (2005)

High-Power Fiber-Feedback Parametric Oscillator

- Parametric oscillators allow to generate broadly wavelength-tunable radiation and/or to access various wavelength regions
- Achievement: demonstrated a novel kind of synchronously pumped parametric oscillator which has a number of attractive features
- Key points: compact setup due to the use of a fiber; remarkable insensitivity to intracavity losses and to cavity length mismatch
- Refs.:
 - T. Südmeyer et al., Opt. Lett. **26** (5), 304 (2001)
 - T. Südmeyer et al., J. Phys. D: Appl. Phys. **34** (16), 2433 (2001)
 - T. Südmeyer et al., Opt. Lett. **29** (10), 1081 (2004)

High-Power Nonlinear Pulse Compression

- Spectral broadening of pulses in optical fibers allows significant reduction of the pulse duration and increase of the peak power
- Achievement: extension of the method into the power regime well above 10 W (av.)
- Key points: use of novel large mode area microstructure fibers; numerical simulation of pulse propagation
- Ref.: T. Südmeyer et al., Opt. Lett. **28** (20), 1951 (2003)

Fluctuations and Noise

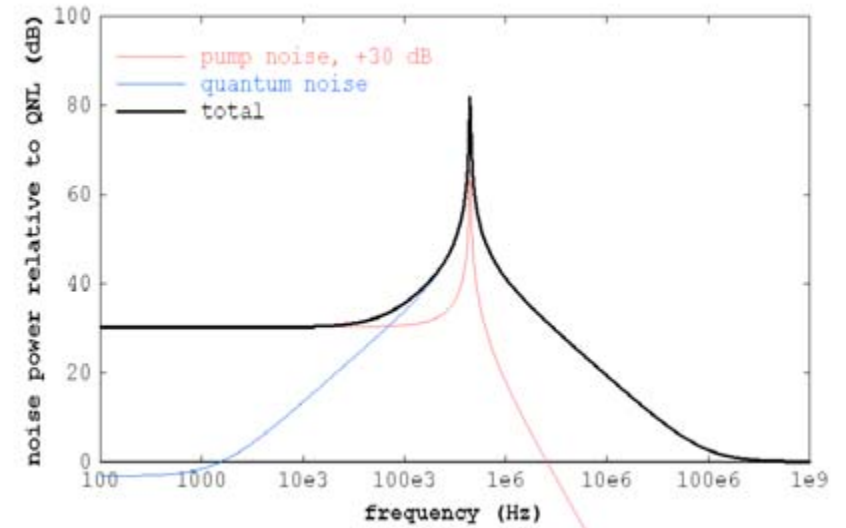
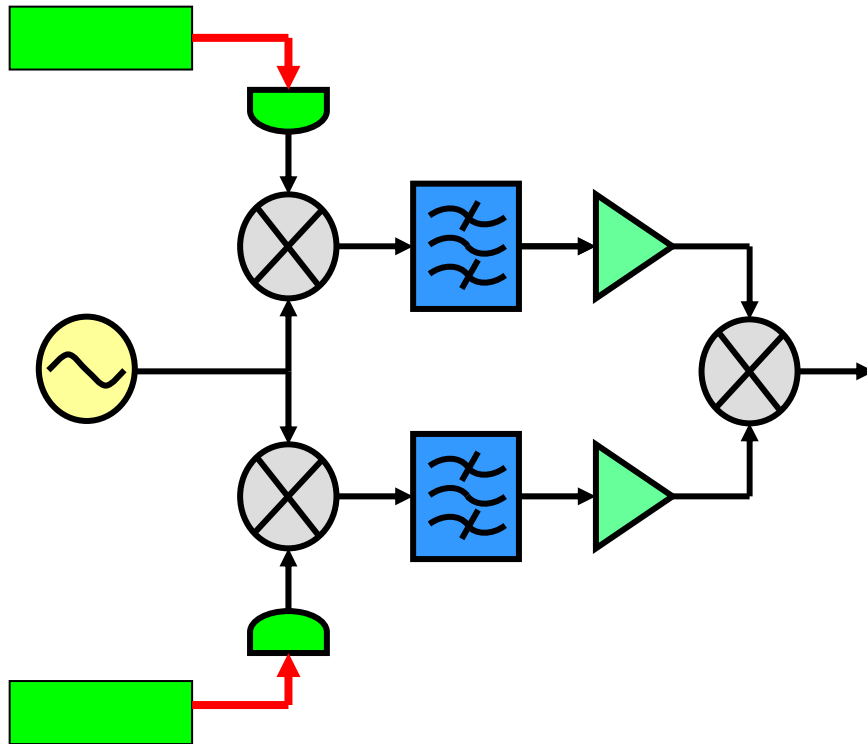

$$\sigma_{cc}^2 = \frac{1}{f_0^4} \int_{-\infty}^{+\infty} f^2 S_{\phi}(f) \operatorname{sinc}^2 \left(\pi \frac{f}{f_0} \right) df$$

Quantum Noise Reduction in Singly Resonant Frequency Doublers

- Most optical measurements can not be done with noise levels below the standard quantum limit. However, certain nonlinear techniques allow the generation of nonclassical states of light with lower noise.
- Achievement: development of a new scheme for the generation of nonclassical light with high average power, based on a singly (rather than doubly) resonant frequency doubler.
- Key points: finding a novel scheme which some theoreticians had not believed to be viable; development of low-loss monolithic frequency doublers; careful noise measurements
- Ref.: R. Paschotta et al., Phys. Rev. Lett. **72** (24), 3807 (1994)

Understanding of the Noise Properties of Mode-Locked Lasers

- Timing noise is very important for many applications, e.g. in telecommunications, optical sampling, etc.
- Achievements: development of numerical techniques for timing noise modeling (applied to bulk and fiber lasers); developed comprehensive picture of various noise sources and their interactions; developed a sensitive and versatile measurement technique
- Key points: solved various numerical problems; understanding of quantum noise influences; mathematical tools for pulse propagation modeling

Understanding of the Noise Properties of Mode-Locked Lasers

- Refs.:
 - R. Paschotta, “Noise of mode-locked lasers”, paper in two parts, Appl. Phys. B **79**, pp. 153–173 (2004)
 - R. Paschotta et al., “Relative timing jitter measurements with an indirect phase comparison method“, Appl. Phys. B **80** (2), 185 (2005)
 - R. Paschotta et al., “Optical phase noise and carrier-envelope offset noise“, Appl. Phys. B **82** (2), 265 (2006)
 - R. Paschotta et al., “Timing jitter of mode-locked fiber lasers”, Advanced Solid-State Photonics 2009 in Denver, poster MB16
 - O. Prochnow, R. Paschotta et al., “Quantum-limited noise performance of a femtosecond all-fiber ytterbium laser”, Opt. Express **17** (18), 15525 (2009)

Effect of Intracavity Distortions on Laser Beam Quality

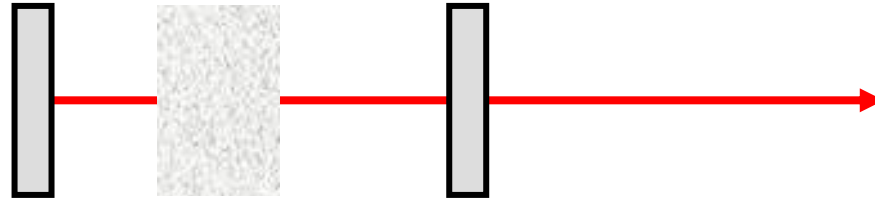

- Beam quality of lasers is deteriorated by the effect of distortions, particularly in the gain medium (→ thermal lensing with aberrations)
- Achievements: clarified how exactly intracavity distortions translate into beam quality degradation via coherent mode coupling; explained long known but previously not understood experimental observations; found new criteria for optimization of beam quality via resonator design
- Key points: deep understanding of laser resonators and classical optics; realized connections between previously unrelated phenomena

Ref.: R. Paschotta, Opt. Express 14 (13), 6069 (2006)

Power Scaling of Lasers

- Terms like “power scaling” of lasers and “scalability” of laser architectures have often been used, but surprisingly without clear definitions until 2007.
- R. Paschotta has worked out a solid basis for the concept of power scaling.
- It is based on a scaling procedure, which is a systematic procedure for transforming some working laser design into another design with substantially higher power, without making any of the main technical challenges more severe.
- Scalability then means the existence of a scaling procedure. Most laser architectures are *not* power scalable.
- It is useful to also consider scaling properties of isolated aspects or techniques within a laser architecture.

Ref.: R. Paschotta, “Power scalability as a precise concept for the evaluation of laser architectures”, arXiv:0711.3987v1, <http://www.arxiv.org/abs/0711.3987>